

YX53 系列语音芯片

产品规格书

4/8 接口单信道语音芯片

YX53005/YX53010/YX53020/YX53040/YX53080
YX53080F/YX53160F/YX53320F/YX53640F

公司名：深圳市宇芯科技发展有限公司

地址：深圳市宝安区新安街道43区佳运达大厦4楼409

电话：0755-26416647

传真：0755-26645695

QQ： 124202580 3037440948

邮箱：124202580@qq.com 3037440948@qq.com

网址：www.yuxinic.com

产品概观

YX53系列为全新世代高性价比的语音芯片，具有 9bits 高性能 PWM/DAC 语音引擎。并且具备有 5~640 秒(6K/4bits)多样化的型号选择，并内置有高精度起振器，毋需外部起振组件，外接组件少，让应用开发整体成本具有市场领先的优势。

功能概观

语音引擎：9bits PWM. / 9bits DAC(部分型号无 DAC 功能)

可编辑阶数：3800 阶

可编辑群组数：63 组(最大)

开机执行群组：1 组

可放声音长度：5 (YX53005) / 10 (YX53010) / 20 (YX53020) / 40 (YX53040) / 80 (YX53080) / 80 (YX53080F) / 160 (YX53160F) / 320 (YX53320F) / 640 (YX53640F)
4bits@6K-Playrate

四组可设定接口

- TG1 带序列模式一般输入接口。
- TG2 可设定为低准位触发复位接口。
- TG2 带序列模式一般输入接口。
- TG3 一般接口，可程序化为音量调整接口 (部分型号)
- TG4 一般接口 (部分型号)

· 可程序化接口触发型态

- Re-triggered / Irre-triggered.
- Level / Edge.
- Hold / Un-hold.
- Voice Repeat / One-time voice.
- On/Off function.

· 选表式声音压缩编码引擎

- 4bits / 5bits / 8bits / 9bits

内置单片机触发模式 SPI 接口

内置 RC 震荡起振回路，无须外部电路

宽工作电压：2.0~5.0V

工作温度：-20℃ ~ 60℃ (不计工作频率飘移)

- . 简易编程功能
 - . 工作寄存器写入
 - . 工作寄存器进位
 - . 工作寄存器比较分支
- . 可程序化输出状态
 - . 待机准位
 - . 工作高准位
 - . 工作低准位
 - . 输出频闪

- . 多样化播放速率选择
 - . 3.1K / 3.2K / 3.3K / 3.5K / 3.7K / 3.8K
 - . 4.0K / 4.2K / 4.4K / 4.6K / 4.8K
 - . 5.0K / 5.3K / 5.6K
 - . 6.0K / 6.4K / 6.8K
 - . 7.4K / 8.0K / 8.7K / 9.6K / 10.6K / 12.0K
 - . 13.7K / 16.0K / 19.2K / 24.0K / 32.0K

Body overview 母体比较表

Body / 母体	Duration/预估秒数	IO counts / 接口数
YX53005	5" @6K/4bits	2
YX53010	10" @6K/4bits	2
YX53020	20" @6K/4bits	2
YX53040	40" @6K/4bits	4
YX53080	80" @6K/4bits	4
YX53080F	80" @6K/4bits	3
YX53160F	160" @6K/4bits	3
YX53320F	320" @6K/4bits	3
YX53640F	640" @6K/4bits	3

脚位功能:

PIN NAME	ATTR	FUNCTION
PWM2/DAC	0	PWM 输出脚 2 (接喇叭) 或 DAC 输出脚
PWM1	0	PWM 输出脚 1 (接喇叭)
VDD	POWER	电源正极
VSS	POWER	电源负极
VDDS	POWER	外接闪存 (SPI FLASH) 电源
TG1	I/O	TG1 / SPI DI
TG2	I/O	TG2 / 低电平复位 / SPI SCK
TG3	I/O	TG3 / SPI DO
TG4	I/O	TG4 / SPI CS

封装脚位图

YX53020 / YX53010 / YX53005 SOP8

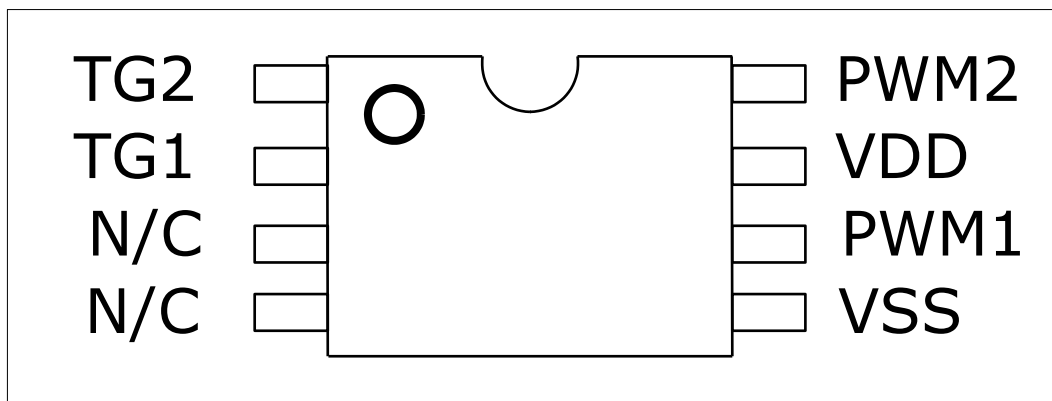

YX53040 SOP8

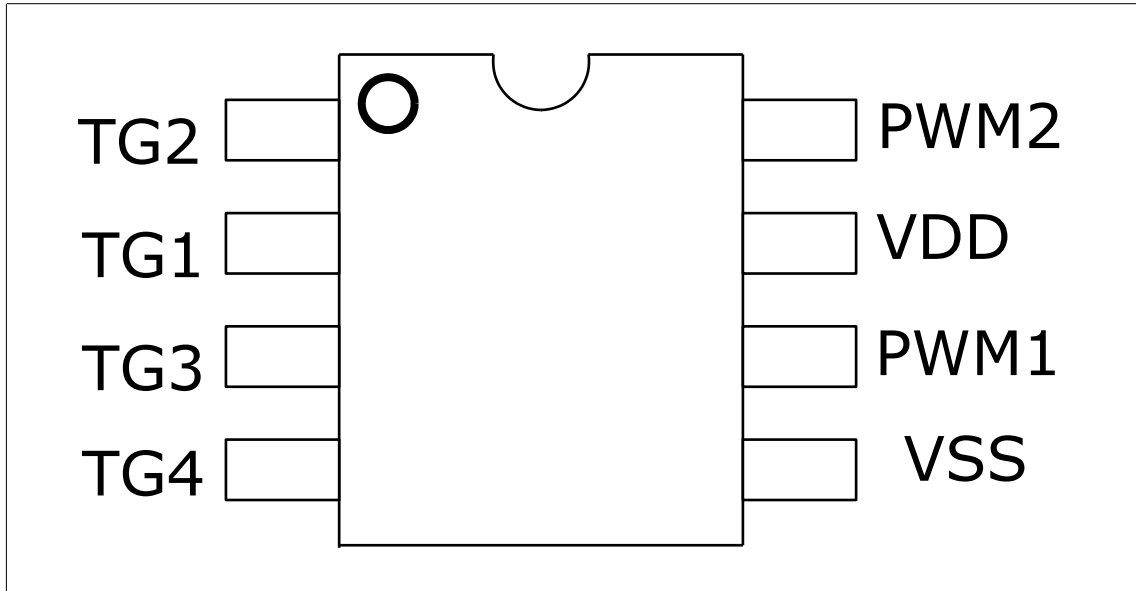

YX53080 SOP8

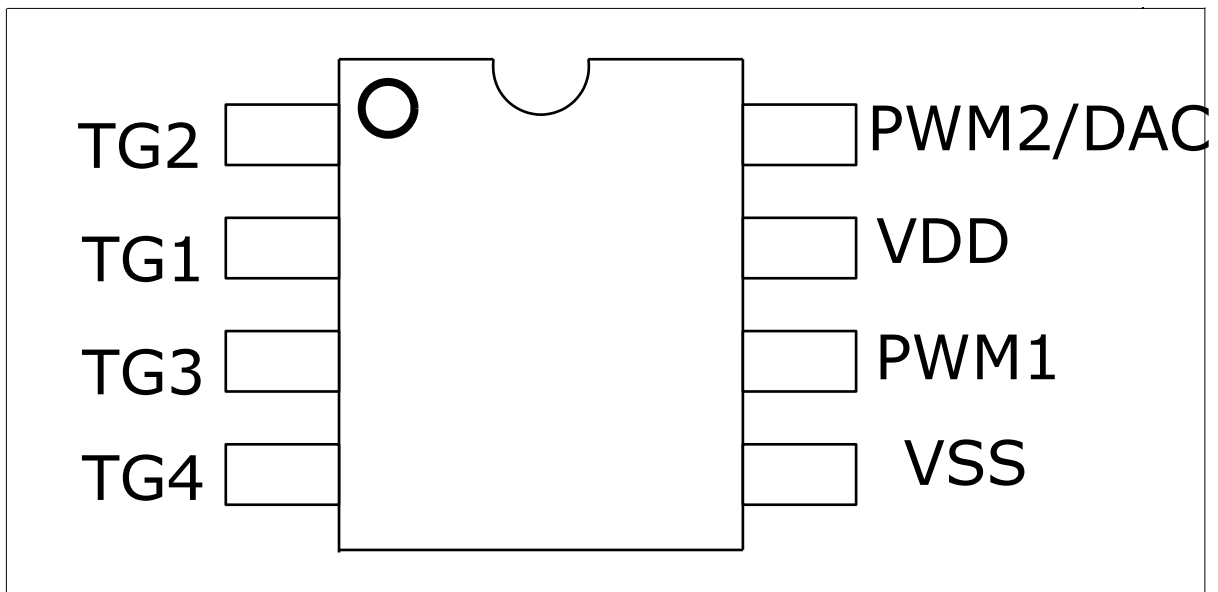

YX53080FA/YX53160FA/YX53320FA/
YX53640FA SOP8

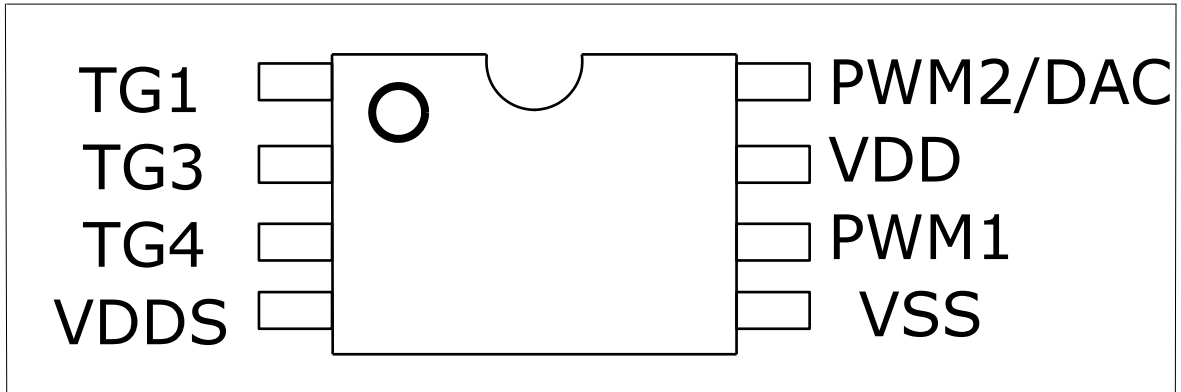

YX53080FB/YX53160FB/YX53320FB/
YX53640FB SOP8

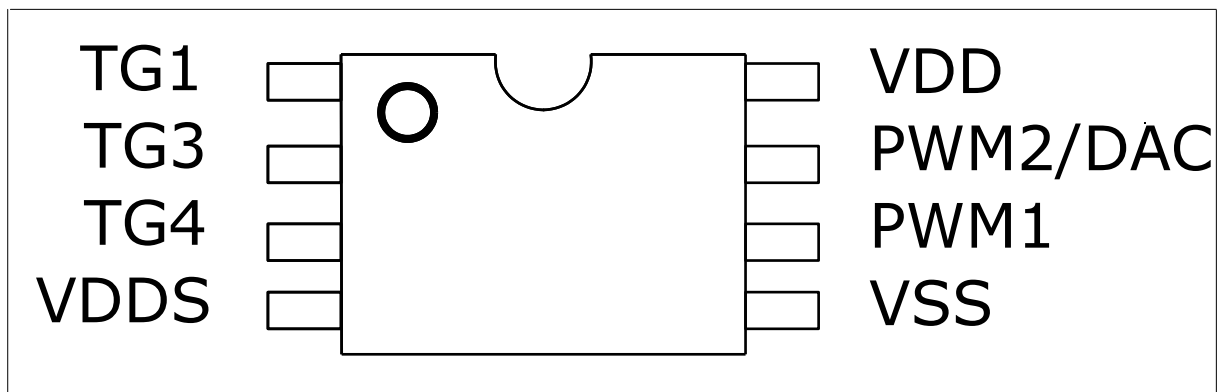

应用线路图

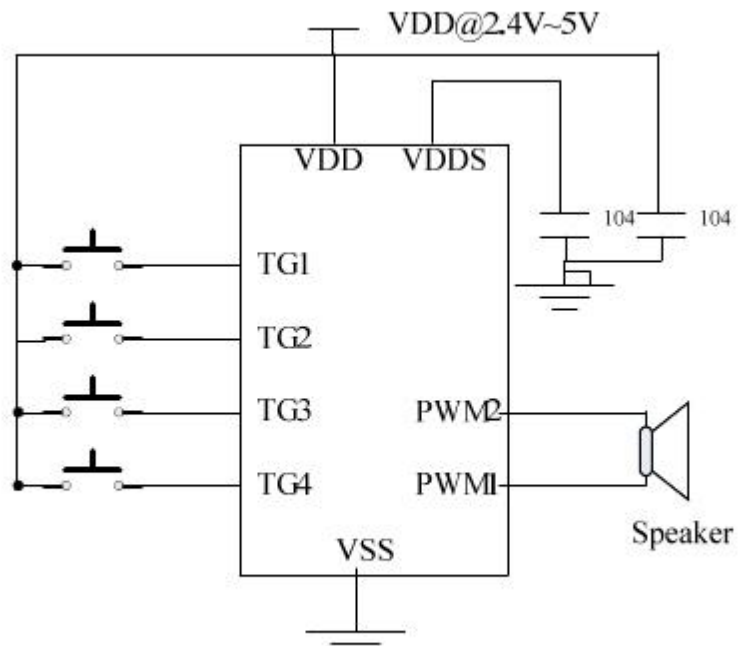
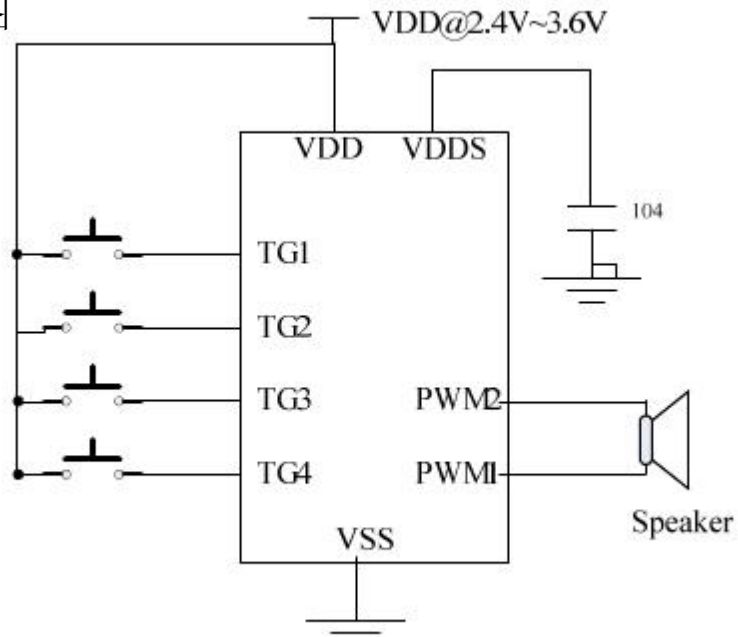

Trigger Timing

(a) Trigger Pulse Width < Group Length

Option Setting = Edge / Unhold

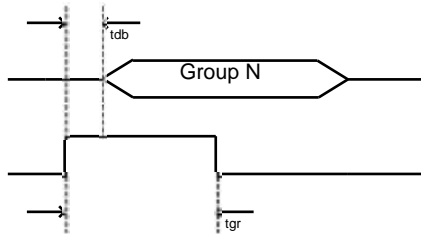

(b) Trigger Pulse Width < Group Length

Option Setting = Edge / Hold

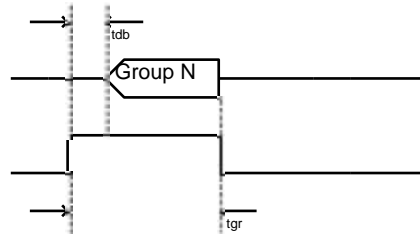

(c) Trigger Pulse Width < Group Length

Option Setting = Level / Unhold

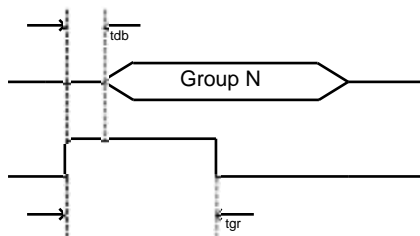

(d) Trigger Pulse Width < Group Length

Option Setting = Level / Hold

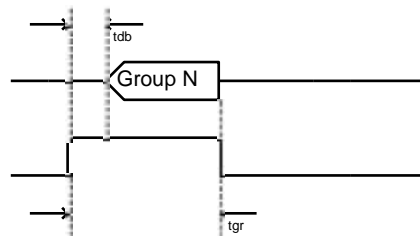

(e) Trigger Pulse Width > Group Length

Option Setting = Edge / Unhold

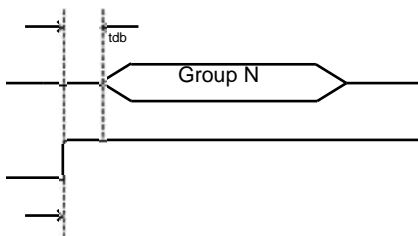

(f) Trigger Pulse Width > Group Length

Option Setting = Edge / Hold

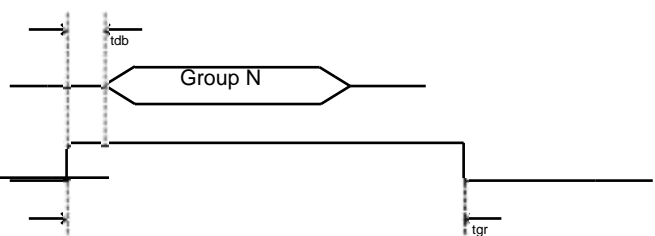

(g) Trigger Pulse Width > Group Length

Option Setting = Level / Unhold

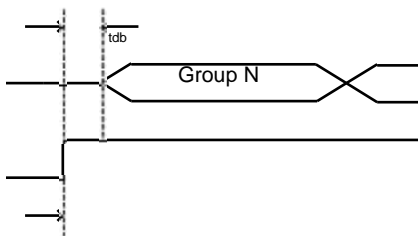

(h) Trigger Pulse Width > Group Length

Option Setting = Level / Hold

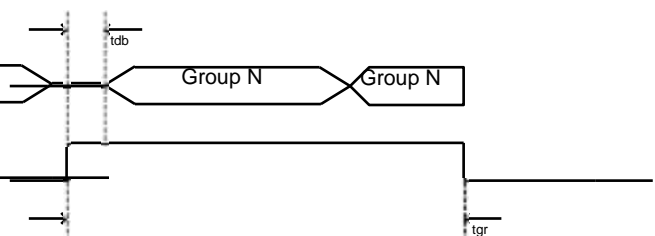

(i) Option Setting = Retrigger

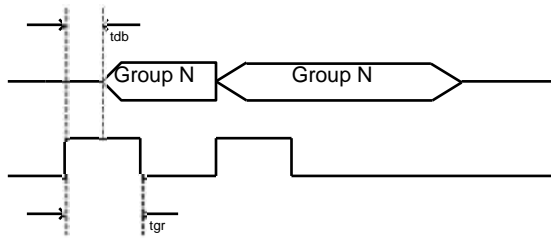

(j) Option Setting = Irretrigger

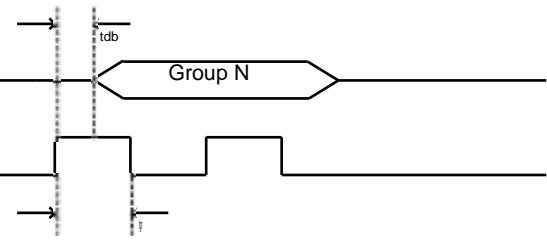

(k) TG1 = Sequential Trigger & From Group1~Group5

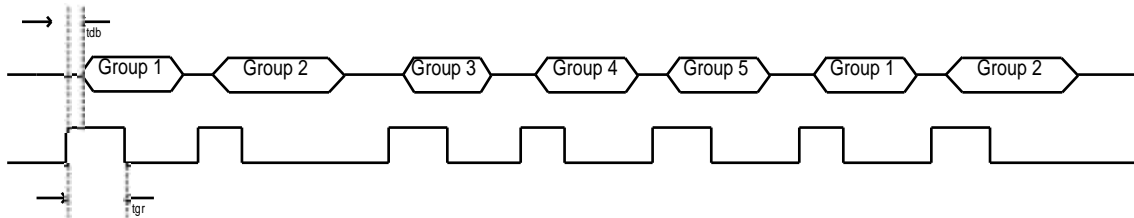

↗ Trigger Voice Combination Example

Voice File	Description
Voice File A	Hello (1.5'')
Voice File B	Good Morning (3'')
Voice File C	John (1'')
Voice File D	Tom (1'')
Voice File E	Mary (1.5'')

Group1 = Step1 + Step 2

Group 2 = Step3 + Step 4 + Step 5

Group 3 = Step 6 + Step 7

Group1 = Hello John

Group 2= Hello Tom Good Morning

Group 3 = Good Morning Mary

Step1 = Voice File A

Step 2 = Voice File C

Step 3 = Voice File A

Step 4 = Voice File D

Step 5 = Voice File B

Step 6 = Voice File B

Step 7 = Voice File E

Total use 3 Group , 7 Steps

Voice duration= Hello + Good Morning + John + Tom + Mary

$$= 1.5'' + 3'' + 1'' + 1'' + 1.5''$$

$$= 8''$$

Total duration = 8'' (40''-8'' = 32'' space are free , can add more Voice File, If body=V53040)

Serial Mode Timing

TG1=Pulses

TG3=Re-Pulses

TG4=Busy_H

*TG2=Reset PIN

★ one line

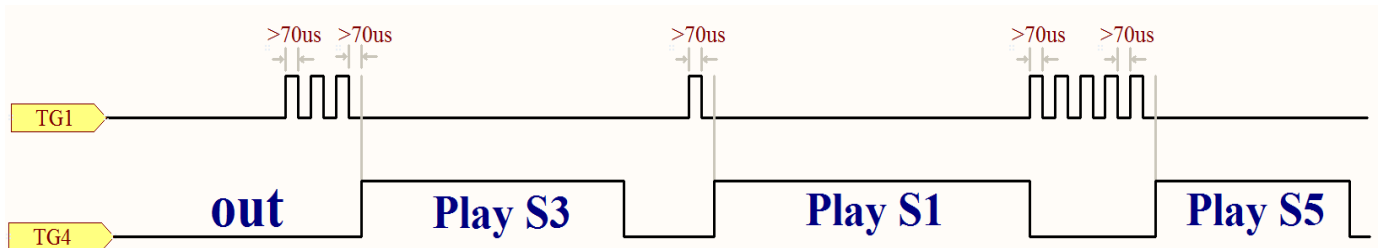

★ two lines

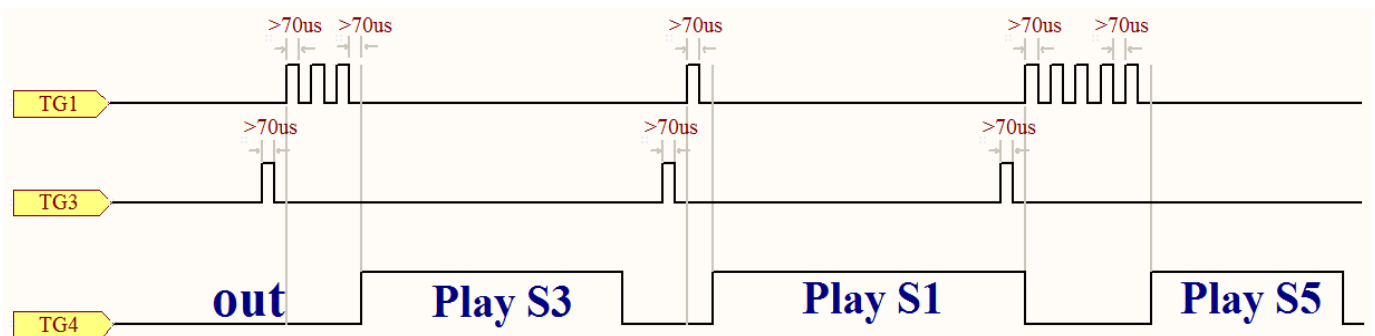

MCU Mode Timing

TG1 = DI , TG2 = SCK , TG3 = DO , TG4 = CS

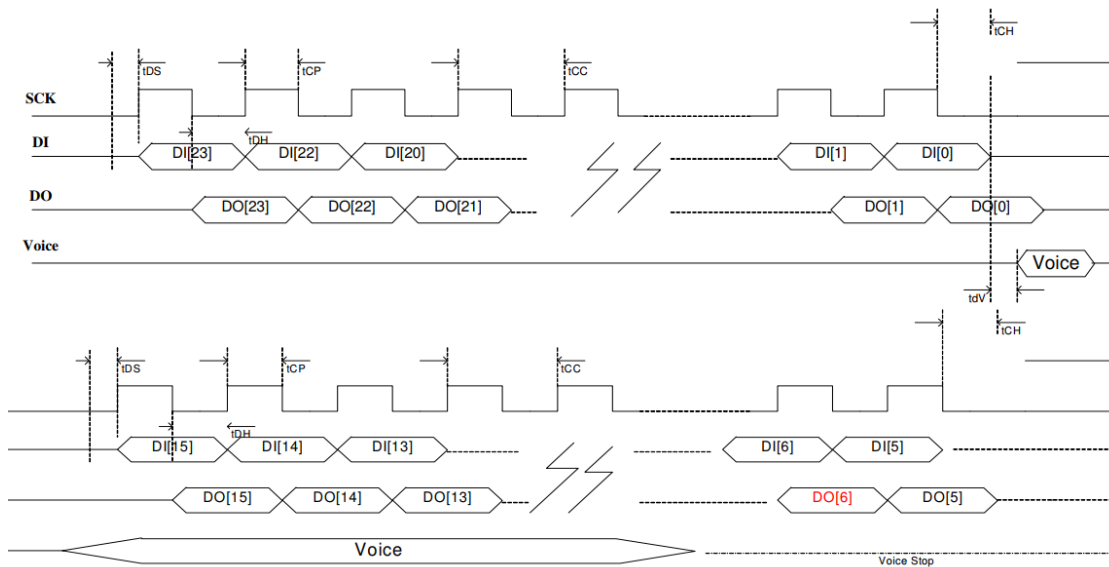

* **DO[6]** = 1 is Busy , =0 Voice Stop

MCU mode command table

Command	PIN	Command Data	Clock Count	Description
Initial	DI	0x1E525B	24 clk	Wake up the chip
	DO			
START	DI	0x0A0140	24 clk	Wake up the chip
	DO			
STOP	DI	0x0A0100	24 clk	Stop up the chip
	DO			
PLAY	DI	0x18+Group Address Ex:0x00C8	24 clk	Play Voice Step Address
	DO			
PAUSE	DI	0x0A0148	24 clk	Pause the Playback and hold at the Voice data
	DO			
RESUME	DI	0x0A0140	24 clk	Resume Playback from the previous Voice data
	DO			
Read Busy	DI	0x2200	16 clk	Check Voice is Stop or Not (V53005/010/020 no support)
	DO	Check DO[6]		
Change Volume	DI	0x0A05+Volume(00~07) Ex: Volume = 5 , DI = 0x0A0505	24 clk	
	DO			

Play Address Command is generated by the Tool.

Symbol	Characteristic	Min.	Unit
tdb	Key Trigger debounce time (long)	14	ms
tdb	Key Trigger debounce time (short)	50	us
tBH	Busy signal output hold time	200	us
tBD	Busy signal output delay time	200	us
tdV	Voice output delay time	200	us
tCS	Chip Select setup time	1	us
tDS	Data In setup time	1	us
tDH	Data In hold time	1	us
tCP	Clock Pulse Width	1	us
tCC	Clock Cycle time	2	us
tCH	Chip Select hold time	1	us

DC Characteristics

Symbol	Parameter	Condition	Min	Typ	Max	Unit
V _{OP}	Operating Voltage		2.0		5.0	V
I _{sb}	Standby current	LDO On		1		uA
		LDO OFF		3		uA
I _{OP}	Operating Current	VDD=3V / No Load		300		uA
I _{OD}	Output drive Current			5		mA
I _{OS}	Output sink Current			9		mA
I _{ODPWM}	PWM output drive Current			200		mA
I _{OSPWM}	PWM output sink Current			200		mA